

Travel Limit Adjustment

WARNING

To prevent **SERIOUS INJURY** or **DEATH** from improper Force Adjustment:

- Improper adjustment of travel limits will cause operation of safety reversal mechanism.
- If Travel limit adjustment is made, Force Adjustment may also be needed.
- After **ANY** adjustments, the Safety Reverse Test **MUST** be performed to ensure the door reverses on contact with a 1-1/2" thick object (2x4 laid flat).

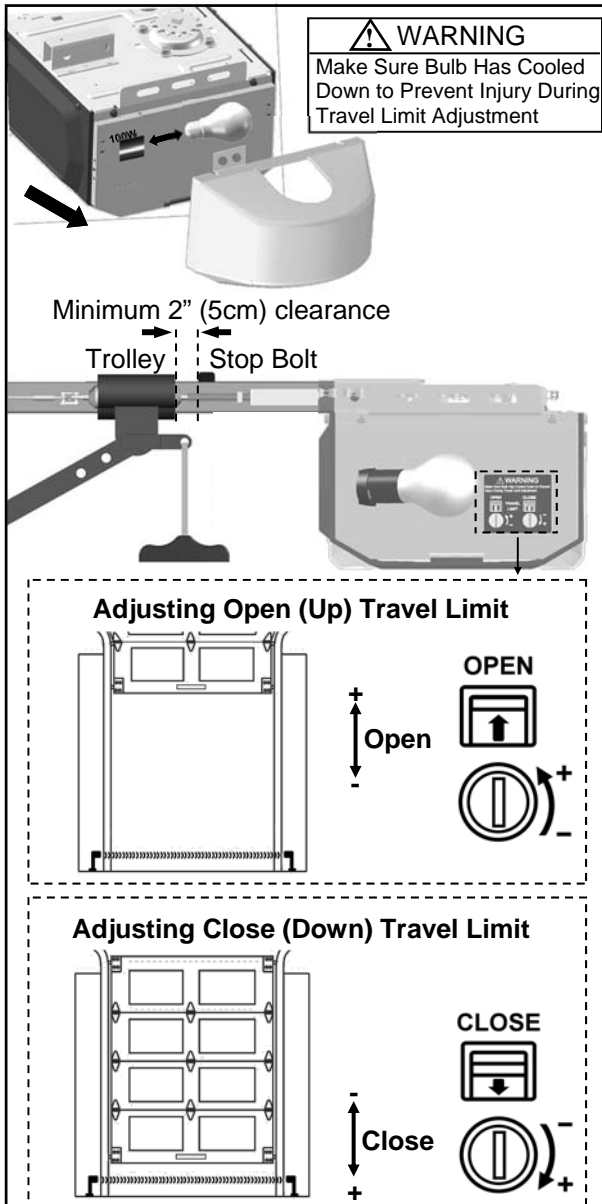

About Travel Limits

Limit Adjustments regulate the position at which the door will stop when opening and closing.

BEFORE making any adjustments, operate the door by using the push button or Transmitter. Run the Opener through a complete cycle.

If the door opens and closes completely without unintended reversing upon closing — NO adjustment is necessary.

If the door does not open or close at desired positions, proceed with the instructions below to adjust the travel limits.

Adjusting Travel Limits

The Limit Adjustment is located inside the left light lens. By pulling out and down detach the light lens from the Opener.

Open and Close Limits can be increased (+) or decreased (-) by turning the corresponding screws on the Opener. Use a "flat head" screwdriver to make adjustments. One full turn of the screw is about 2" (5cm) of actual travel.

NOTE: The Opener motor includes an automatic thermal protection system which will shut down the motor in an overheat situation. The thermal protector will reset itself once the motor cools down. Opening and closing the Opener multiple times (in a short period of time) may cause the motor to overheat and shut down. If this happens, wait about 20 minutes for the motor to cool and retry operation.

Setting OPEN (UP) Travel Limit

1. CLOSE the garage door by using either the Transmitter or Push Button.
2. Adjust the OPEN Limit Screw.
3. OPEN garage door and check for proper adjustment.
4. Repeat steps 1-3 until the door opens to the desired position. When the door is in the open position, make sure there is enough clearance for your vehicle(s), and there is a minimum 2" (5cm) gap between Trolley and Stop Bolt.
5. Perform **Safety Reverse Test** on page 18.

If the door does not open past 5 feet (1.5m), follow **Force Adjustment** on page 17 to adjust the Open Force.

Setting CLOSE (DOWN) Travel Limit

1. OPEN the garage door by using either the Transmitter or push button.
2. Adjust the CLOSE Limit Screw.
3. CLOSE the garage door and check for proper adjustment.
4. Repeat steps 1-3 until door closes to the desired position.
5. Perform **Safety Reverse Test** on page 18.

If the door reverses unintentionally during closing, check below symptoms:

1. The Photo Eye System may be improperly connected, misaligned or obstructed. The courtesy light will flash continuously for 30 seconds. Refer to **Troubleshooting** on P.22.
2. Binding door — Disconnect the door from the Opener by using the Emergency Release Handle. Open and close the door manually and check the following steps.
 - 2.1 If the door is balanced, refer to "Force Adjustment" to adjust Close force.
 - 2.2 If the door is unbalanced, binding or jammed, call a trained service person to adjust the door.

Force Adjustment

WARNING

To prevent **SERIOUS INJURY** or **DEATH** from improper Force Adjustment:

- **DO NOT** adjust force to compensate for binding or sticking of the garage door. Call a qualified garage door service technician to make necessary adjustments in case of binding.
- **DO NOT** increase the force beyond minimum force required for closing the door. Too much force will cause improper operation of safety reversal mechanism.
- If either the Force or Travel limit adjustment is made, the other adjustment may also be needed.
- After **ANY** adjustments, the Safety Reverse Test **MUST** be performed to ensure the door reverses on contact with a 1-1/2" thick object (2x4 laid flat) .

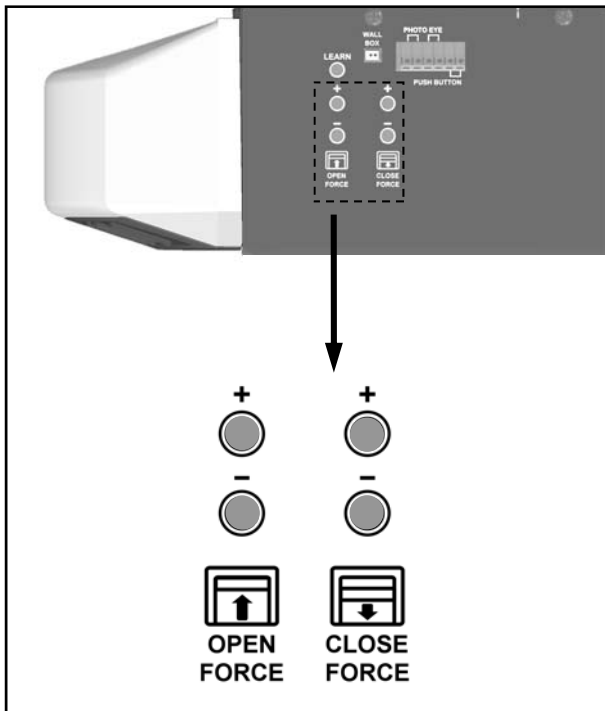

For safe operation, the force setting should always be set at the MINIMUM FORCE required to run the door.

Adjusting Force

1. Force Adjustment controls are located on the rear panel of the Opener. The force adjustments regulate the amount of force required to open or close the door.
2. Force Adjustment is applied only to compensate for the minor resistance caused by weather or other means.
 - Note: Force is preset at level 6 for both Open and Close adjustments. The size and operating conditions of the garage door will determine the correct level of Force/Sensitivity. Weather conditions may also affect the operation of the door requiring further adjustments as needed.
 - Note: If the close force is set too light the Opener will reverse the door during closing. If the open force is set too light the Opener will stop the door during opening.
 - Note: There are 12 levels for open and close force settings. When either the maximum or minimum level is reached, the light will flash 6 times.
 - Never adjust the force setting by more than 1 level (1 press) at a time.

Setting Force

Setting Close Force

1. If the door completes a full close cycle without reversing, decrease (-) the Close Force by 1 level at a time until the door reverses. If the door reverses during closing, increase (+) Close Force by 1 increment. The Close Force is now properly adjusted.
2. During the "door-close" cycle, the Opener will reverse if the force required to close the door is exceeded.

Setting Open Force

1. If the door completes a full open cycle without stopping, decrease (-) the amount of force by 1 level until the door stops during the opening. Once the door stops during opening, increase (+) Open Force by 1 increment. The Close Force is now properly adjusted.
2. During the "door-open" cycle the Opener will stop if the force required to open the door is exceeded.

Final Adjustments and Testing

WARNING

To prevent **SERIOUS INJURY** or **DEATH** from a closing garage door:

- The Safety Reversal Test **MUST** be conducted **ONCE A MONTH**.
- **NO ONE** should cross the path of moving door during operation and/or testing.
- If either Force or Travel limit adjustment is made, the other adjustment may also be needed.
- After **ANY** adjustments to the door system, the Safety Reverse Test **MUST** be performed to ensure the door reverses on contact with a 1-1/2" to 3" thick solid object.
- The Photo Eye Safety System **MUST** be properly aligned, and tested regularly.

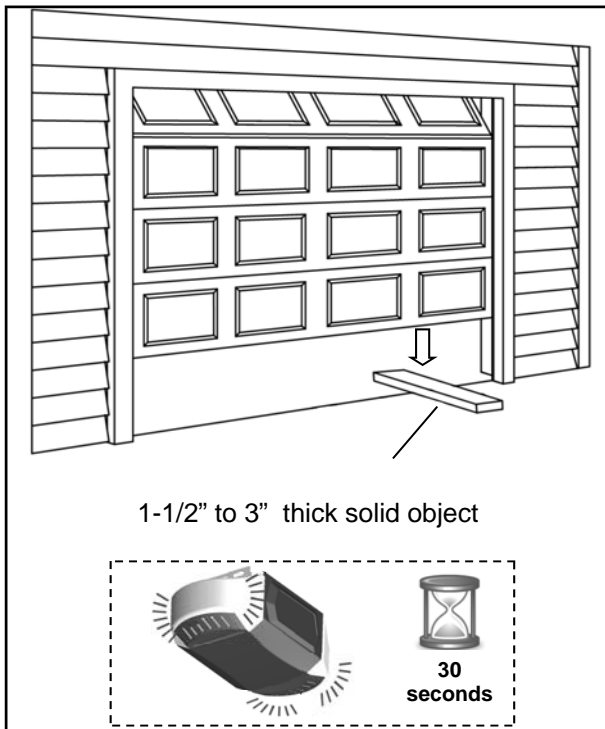

Testing the Safety Reverse System

The Safety Reverse System prevents the door from closing when an obstruction is present.

1. Open the door by using the push button or Transmitter
2. Place a 1-1/2" to 3" thick solid object on floor under the center of garage door.
3. Keeping the door in sight, use the push button or Transmitter to close the door.
4. The door **MUST REVERSE** upon striking the object within 1.5 seconds, and stop at the fully opened position.
5. The courtesy light will start flashing for 30 seconds upon triggering the Safety Reverse System.

If the door just stops on the object, adjust the Opener as follows:

The close travel maybe inadequate, Increase Close travel limit by 1/4 turn (See **Limit Adjustment** on page 16)

Conduct the test again. If the door reverses on contact, remove the object and run at least 3 **COMPLETE** travel cycles to ensure proper adjustment.

If the door still does not reverse on the object, decrease the Close Force (see **Force Adjustment** on page 17) and repeat the test.

If the Opener still fails the Safety reverse Test, call a qualified technician for door adjustment.

Testing the Photo Eye Safety System

1. Open the door by using the push button or Transmitter
2. Make sure both Photo Eyes steadily emit the green and red indicator lights. (If not, check alignment)
3. Place an object under the door about 8" (20cm) high by 12" (30cm) wide (the Opener carton can be used),
4. The green indicator on emitter eye will flash and the red indicator light on the sensor eye should be dimmed.
5. Keep the door in sight and use the push button or Transmitter to try to close the door.
6. The door should **NOT** move more than 1" (2.5cm) and the courtesy light should flash for 30 seconds.

